

Hex Nut & Washer Style

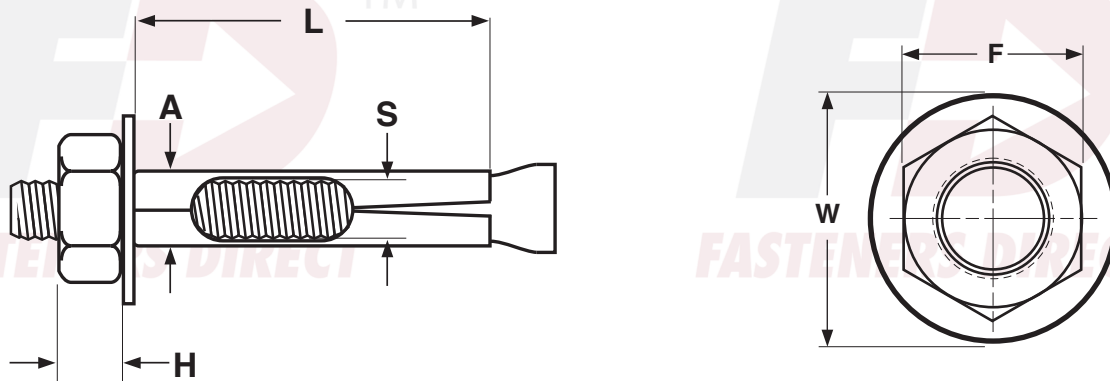

| SLEEVE ANCHORS, HEX HEAD | | | | | | | | | | FF-S-325, Group II, Type 3, Class 3 | |
|----------------------------------|--------------------|--------------------|---------------------|-------------------|------------------------------|----------------------|--------------------------------|--------------------------------------|--------------------|-------------------------------------|-----------------------------|
| A x L Anchor Diam x Length | H Nut Height | F Head Width | W Washer O.D. | Drill Diameter | Fixture Clearance Hole | Minimum Embedment | S Thread Size of Stud | Required Torque to Set (Ft. Lbs.) | | Tensile Strength (psi.) | Shear Strength (psi.) |
| | Ref | Ref | Ref | | | | | Carbon Steel | Stainless Steel | 4000 psi. Concrete Strength | |
| 5/16 x 1 1/2 | 7/32 | 7/16 | 5/8 | 5/16 | 3/8 | 1 3/8 | 1/4-20 | 8 | - | - | - |
| 5/16 x 2 1/2 | | | | | | 1 1/2 | | | - | 1750 | 2015 |
| 3/8 x 1 7/8 | 17/64 | 1/2 | 13/16 | 3/8 | 7/16 | 1 5/8 | 5/16-18 | 16 | 11 | 2700 | 3250 |
| 3/8 x 3 | | | | | | | | | | | |
| 3/8 x 4 | | | | | | | | | | | |
| 1/2 x 2 1/4 | 21/64 | 9/16 | 1 | 1/2 | 9/16 | 2 1/8 | 3/8-16 | 28 | 20 | - | - |
| 1/2 x 3 | | | | | | 2 1/4 | | | | 5015 | 6372 |
| 1/2 x 4 | | | | | | | | | | | |
| 1/2 x 6 | | | | | | | | | | | |
| 5/8 x 2 1/4 | 7/16 | 3/4 | 1 3/8 | 5/8 | 11/16 | 2 1/8 | 1/2-13 | 60 | 42 | - | - |
| 5/8 x 3 | | | | | | 2 3/4 | | | | 6345 | 10,255 |
| 5/8 x 4 1/4 | | | | | | | | | | | |
| 5/8 x 6 | | | | | | | | | | | |
| 3/4 x 2 1/2 | 35/64 | 15/16 | 1 3/4 | 3/4 | 15/16 | 2 1/8 | 5/8-11 | 90 | 60 | - | - |
| 3/4 x 4 | | | | | | 3 3/8 | | | | 9135 | 12,800 |
| 3/4 x 5 3/4 | | | | | | | | | | | |

| | | |
|-------------------------------------|--|---|
| Description | A device for giving stability to one part of a structure by making it fasten to another. It consists of (A) a threaded stud with a conical end flared outward; (B) a hollow, cylindrical dilating sleeve assembled over the stud and positioned against the minor diameter of the cone; (C) a washer and hex nut assembled at the end opposite the cone. | |
| Applications/ Advantages | The anchor works by expanding against the material in which it is embedded. When the hex nut is tightened the conical end is pulled into the dilating sleeve pushing it outward 360° around the anchor into the masonry. They are designed to be used in solid or hollow masonry, including cinder block, brick, marble and concrete. One advantage of the sleeve anchor is that it can be removed after it's been installed. Another is that the length of the sleeve induces less stress on the substrate than does a wedge anchor. It is well-suited for permanently anchoring heavy equipment to concrete. | |
| Material | <p><i>Steel</i></p> <p>Threaded Bolt: AISI 1010 - 1018 cold rolled steel Sleeve: AISI 1008 cold rolled steel Nut: Shall be made from a low carbon steel which conforms to the following chemical composition requirements: <i>Carbon-</i> 0.58% maximum; <i>Phosphorus-</i> 0.13% maximum; <i>Sulfur-</i> 0.23% maximum Washer: AISI 1008 - 1010 cold rolled steel</p> | <p><i>Stainless</i></p> <p>Threaded Bolt: 18-8 stainless steel Sleeve: Type 304 stainless steel Nut: Type 304 stainless steel Washer: 18-8 stainless steel</p> |
| Anchor Spacing | Anchors should be installed with a minimum of 10 anchor diameters between each other and a minimum of 5 diameters from the edge. | |
| Tensile Strength | The suggested safe working load is one-fourth of the average proof test load shown in the above table. | |
| Shear Strength | The suggested safe working load is one-fourth of the average proof test load shown in the above table. | |
| Plating | Steel sleeve anchors are usually supplied plated zinc. | Stainless sleeve anchors usually have no additional finish applied. |